

SITRANS T measuring instruments for temperature

SITRANS T transmitter for field mounting

SITRANS TF2 with temperature sensor

Overview



The temperature transmitter SITRANS TF2 integrates three elements in one device:

- a Pt100 resistance thermometer in a stainless steel protective tube,
- a stainless steel housing with a high degree of protection, and
- a built-in transmitter with LCD and three keys for parameterization.

It is used to indicate and monitor the temperature measured at the point of installation.

The SITRANS TF2 is available in an axial and a radial version.

Benefits

- Robust stainless steel housing with two connection versions
- High measuring accuracy
- Precise display with a resolution of $1/100$ °C in the highest measuring range
- Measuring ranges from -50 to +200 °C (-58 ... +392 °F) parameterizable
- Customer-specific lengths and materials possible for the protective tube
- Stainless steel protective tube with high resistance to chemicals
- Signaling of limit violation in the LCD as well as with a red LED

Application

The SITRANS TF2 is used for indicating and monitoring a temperature variable at the point of installation. Applications are all process engineering branches, e.g.:

- Chemical industry
- Energy industry
- Long-distance heating
- Water supply
- Sewage works
- Food industry
- Steelworks and the cement industry
- Pharmaceutical industry
- Biotechnology

Design

The SITRANS TF2 has a stainless steel housing (diam. 80 mm) with protective glass. The stainless steel protective tube with screw socket contains the temperature sensor Pt100. By using stainless steel for the protective tube it displays high chemical resistance, which means that the temperature sensor is well protected against external effects

The protective tube is supplied as standard in lengths of 170 mm or 260 mm; a customer-specific version is also possible. Similarly, the protective tube can be supplied in the material of the customer's choice.

At the rear of the housing is the electrical connection for the voltage supply using a current loop of 4 to 20 mA. The connection is made with plug connectors to EN 175301-803A.

At the front of the housing is the 5-digit display behind a glass cover. Underneath the display are the 3 keys for parameterizing the SITRANS TF2. Above the display are a green and a red LED for indicating the operating status.

The SITRANS TF2 is available in two versions (see "Dimension drawings"):

- In the radial version (type A) the display is fitted in parallel with the protective tube. The display can be rotated by up to $\pm 120^\circ$ relative to the protective tube.
- In the axial version (type B) the display is at right angles to the protective tube. The display can be rotated by 360° relative to the protective tube.

Function

Mode of operation

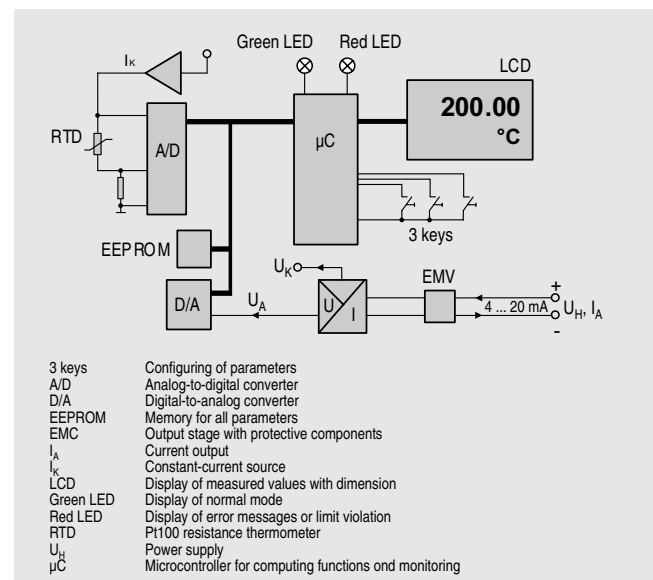

The outside lying temperature sensor Pt100 is supplied with current from the constant current source I_k . A temperature-related voltage drop is thus created over the sensor.

The voltage drop is converted on the analog/digital converter (A/D) into a digital signal.

In the microcontroller (μC) the digital signal is linearized and evaluated in accordance with the data saved in the EEPROM. The processed data are shown in the display.

In addition the values are converted on the digital/analog converter (D/A) and the voltage/current transformer (U/I) into a temperature-linear current signal I_A (4 to 20 mA).

SITRANS T measuring instruments for temperature

SITRANS T transmitter for field mounting

SITRANS TF2 with temperature sensor

Display

Display

The SITRANS TF2 has a 5-digit display behind a glass cover. The following data are shown on the display:

- measured temperature
- unit (°C, °F, °R or K and mA or %)
- limit violation, indicated by LED and arrow symbols in the display

Settings

The SITRANS TF2 is set using the 3 input keys behind the glass cover underneath the display.

The key "M" is used to selected the operating mode. Following modes of operation are available:

- Measured value
- Password
- Unit of measurement
- Start of scale and end
- Upper and lower limit value
- Offset
- Output current calibration
- Upper and lower current saturation limit
- Electrical damping

The other two keys are used to set the values in the individual operating modes.

Monitoring

Two LED indicators are fitted above the display to monitor the set range and the status:

- The green LED signals that the measured temperature lies within the set limits.
- The red LED lights up when the measured temperature lies outside the set limits and when there is an error.

Technical specifications

Measuring principle

Resistance thermometer Pt100 class B acc. to DIN IEC 751

Input

Measured variable Temperature
 Max. measuring range -50 °C ... +200 °C (-58 ... +392 °F)
 Min. measured span 50 K (90 °F)

Output

Output signal 4 ... 20 mA, 2-wire
 Lower current limit min. 3.6 mA
 Upper current limit max. 23 mA
 Output protected against reversed polarity, overvoltage and short-circuiting
 max. load $(U_H - 12 \text{ V}) / 0.023 \text{ A}$
 Voltage measurement Temperature-linear

Measuring accuracy

Error in measurement at 23 °C ± 5 K (73.4 ± 9 °F) $< \pm (0.45 \text{ K} + 0.2\% \text{ of full-scale value in K} + 1 \text{ digit in K})$
 $(< \pm (0.81 \text{ °F} + 0.2\% \text{ of full-scale value in °F} + 1 \text{ digit in °F})$
 Measuring cycle time $\leq 100 \text{ ms}$
 Temperature effect $< \pm 0.15\% / 10 \text{ K} (< \pm 0.15\% / 18 \text{ °F})$
 Power supply effect $< \pm 0.01\% \text{ of full-scale value} / \text{V}$
 Vibration influence $< \pm 0.05\% / \text{g}$ to 500 Hz in all directions (to IEC 68-2-64)

Rated conditions

Ambient conditions

Ambient temperature -25 ... +85 °C (-13 ... +185 °F)
 Temperature range for best readability -10 ... +70 °C (14 ... 158 °F)
 Storage temperature -40 ... +85 °C (-40 ... +185 °F)
 Degree of protection IP65 to EN 60529
 Electromagnetic compatibility EN 61326/A2 Appendix A (2001)

Displays and controls

Display LCD, max. 5 digits, digit height 9 mm (0.354 inch)
 Resolution at max. measuring range 0.01 °C (0.01 °F)
 Decimal point Freely parameterizable
 Limit values Freely parameterizable
 Limit violation display Red LED and message on LCD (↑ symbol / ↓ symbol in case of limit violation in upward / downward direction)
 Parameterization With 3 keys
 Units mA or % or Ω or physical variable: °C, °F, °R, K
 Damping Between 0.1 and 100 s (increment: 0.1 s) freely parameterizable

Design

Weight $\approx 0.7 \text{ kg} (\approx 1.54 \text{ lb})$
 Non-wetted parts materials
 • Field housing Diam. 80 mm (diam. 3.15 inch), stainless steel, mat. No. 1.4016
 • Cover Stainless steel, mat. No. 14016 with glass
 Wetted parts materials
 • Protective tube To DIN 43772 form 8 (March 2000), diam. 14 x 1.5 mm (diam. 0.55 x 0.06 inch)
 - Material Stainless steel (mat. No. 1.4571/316Ti)
 • Protective tube screw socket G½B to DIN 3852-2 form A or ½"-14 NPT
 - Material Stainless steel (mat. No. 1.4571/316Ti)
 Measuring insert Length to fit the ordered protective tube, stainless steel
 Connection of display to the protective tube radial (type A), can be swiveled by max. ±120° (α)
 axial (type B), can be swiveled by max. ±360°
 Length of the protective tube (U_1) see Ordering data
 Electrical connection Using 2-pole plug connector made of plastic with M16x1.5-cable entry to EN 175301-803A or ½"-14 NPT

Power supply

Terminal voltage on temperature transmitter (U_H) 12 ... 30 V DC

Operating limits

Pressure max. 40 bar (580 psi)

SITRANS T measuring instruments for temperature

SITRANS T transmitter for field mounting

SITRANS TF2 with temperature sensor

3

Selection and ordering data	Order No.	Order code
Temperature transmitter SITRANS TF2, field device Temperature transmitter with LCD in stainless steel housing, degree of protection IP65, stainless steel protective tube, resistance thermometer with Pt100 sensor, measuring range -50 ... +200 °C (-58 ... +392 °F), local parameterization, output signal 4 ... 20 mA	7 NG 3 1 4 0 -	
Display / cable entry <ul style="list-style-type: none"> Radial version (type A), parallel to protective tube / M16x1.5 Axial version (type B), at right angles to protective tube / M16x1.5 Radial version (type A), parallel to protective tube / ½"-NPT Axial version (type B), at right angles to protective tube / ½"-NPT 	0 1 2 3 4	
Process connection <ul style="list-style-type: none"> Connection shank G½B Connection shank ½"-14 NPT Other version (on request) add Order Code and plain text: connection shank: ... 	A B Z	J 1 Y
Length of the protective tube (U₁) <ul style="list-style-type: none"> 170 mm (6.70 inch) 260 mm (10.24 inch) 4.5" (114 mm) 7.5" (190 mm) 10.5" (266 mm) Other version (on request) add Order Code and plain text: length: ... 	A B K P T Z	K 1 Y
Material of the protective tube <ul style="list-style-type: none"> Stainless steel (mat. No. 1.4571/316Ti) Other version (on request) add Order Code and plain text: mat. No.: ... 	0 9	L 1 Y

▶ Available ex stock

Schematics

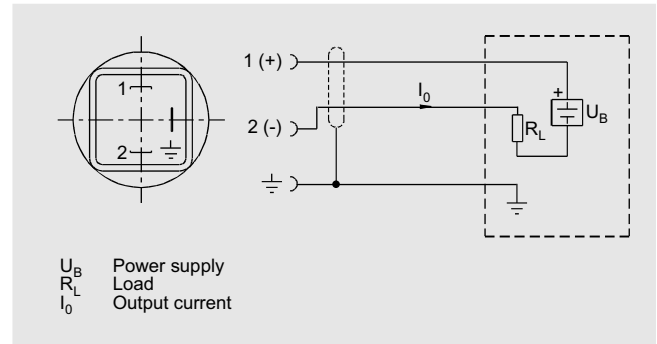

SITRANS TF2, connection diagram

Dimensional drawings

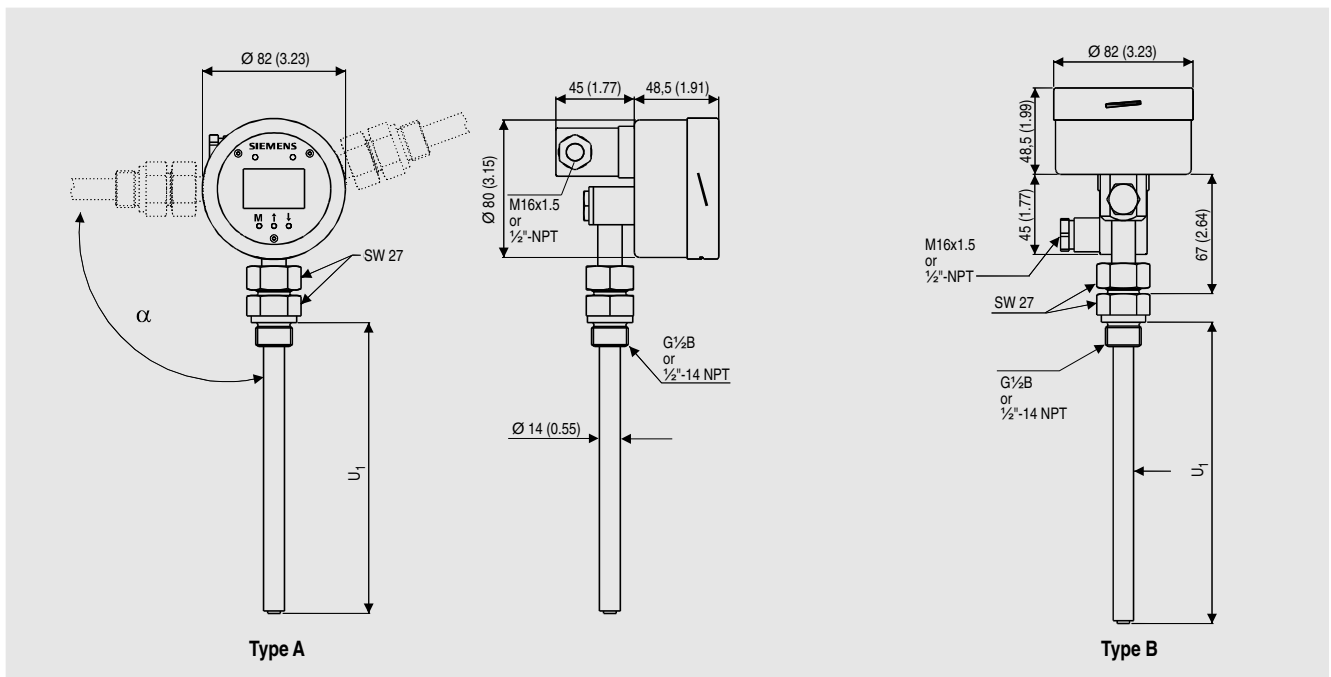

SITRANS TF2, dimensions in mm (inches)