

Sentinel LCT

Panametrics Ultrasonic Flowmeter for Liquid Custody Transfer Measurement

Benefits

- Extremely reliable and highly accurate flowmeter, designed specifically for custody transfer measurements.
- Viscosity independent. Measurement accuracy will not be affected by a change in viscosity or density.
- Fully welded construction with no moving parts. No filters or strainers required.
- Full bore design, zero pressure drop.
- Robust Path Configuration™ through extensive use of CFD (Computational Fluid Dynamics).
- Optionally built-in flow computer for API MPMS 11.1 corrections for temperature and pressure.



Applications

- Custody transfer measurement
- Allocation measurement
- Pipeline leak detection
- Crude oil and refined products



Custody Transfer Flow Measurement from GE

GE introduces Sentinel LCT, a new addition to our series of advanced ultrasonic flowmeters. Sentinel LCT demonstrates new levels of performance and accuracy, reacts to changes in flow rate with incredible speed and is based on proven technology. Sentinel LCT is designed specifically for the custody transfer measurement of crude oil and refined product and meets the strict requirements of API MPMS 5.8, OIML R117-1 and MID MI-005.

It's All About Reliability

The design philosophy behind Sentinel LCT was simple; building a flowmeter that combined absolute reliability with the highest accuracy. Using ultrasonic technology was the first choice; with no moving parts the meter will not suffer from any mechanical wear or tear. Using a fully welded construction without any gaskets or threaded connections was another choice; there is simply nothing in the meter's geometry that can change to allow the meter to drift.

Robust Path Configuration™

Before Sentinel LCT was ever tested on a calibration loop, the meter was already extensively tested in the virtual world. Computational Fluid Dynamics (CFD) was used to simulate different path configurations under different flow scenarios. To give an idea of the level of detail we went into, the CFD was done with the same set-up that GE Aviation uses to model the flow in aircraft engines.

CFD allowed us to test different ultrasonic path configurations under a number of different flow scenarios, from laminar flows that are typically seen in very heavy crudes to highly turbulent flows that are seen in gasoline and LPG applications. Only after CFD simulation provided the optimal path configuration, Sentinel LCT was tested in a calibration loop to prove the CFD results. The result of the CFD is filed as a GE patent and is reflected in the choice of Robust Path Configuration™.

Testing on different viscosity oil products proved the CFD analysis to be right. Sentinel LCT easily met the targeted 0.15% accuracy and, even with the viscosity correction switched off, Robust Path Configuration™ showed an absolute minimum effect on changing viscosities

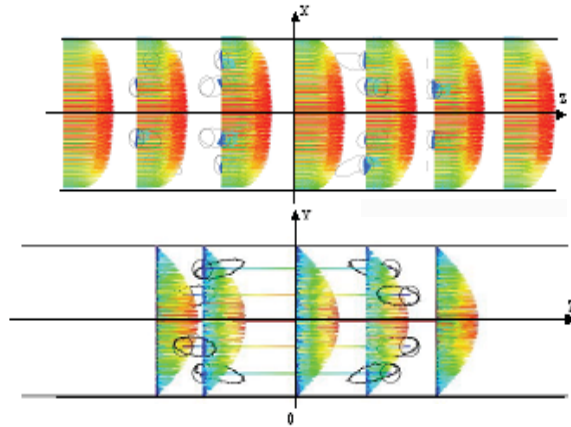

CFD analysis of the ultrasonic port effects. The top graph shows the effect under turbulent flow, the bottom graph under laminar flow conditions. Also note the different flow profiles under these conditions.

A True Multi-viscosity Flowmeter

Starting with a meter that already has a minimal sensitivity to viscosity changes, Sentinel LCT uses a number of proprietary algorithms to even further reduce the viscosity effects. As a result, Sentinel LCT is a true multi-viscosity meter, meaning no prover run or change of settings is required when the viscosity changes. The meter stays within 0.15% accuracy over the whole range between minimum and maximum viscosity.

Maintenance Free

Not only does the meter lack any mechanical parts that require maintenance, the meter also does not require any filter or strainers. Inspecting and replacing clogged filters is not required, simply because they are not there. Theoretically the meter does not even require any recalibrations; however, local legal requirements might require differently.

No Pressure Drop

Due to the unique ultrasonic path configuration, the flowmeter design does not have any diameter reductions. This means the design is completely full bore in the same diameter as your pipeline. As a result the pressure drop over the meter is simply equal to a section of pipe with the same length.

Active Temperature Compensation™

Ultrasonic flowmeters use transit time to determine the liquid or gas flow in a pipeline. Measured transit time consists not only of the time the ultrasonic signal spends in a fluid, but also of a portion of “dead time,” being the time that the electrical signal is converted into an acoustical signal and the time the acoustic signal travels inside the transducer. To allow for the utmost accuracy, Sentinel LCT uses pulse echo to actively measure the dead time. By sending a pulse and measuring its reflection, the dead time is measured in real time rather than using a preset value. As a result of this GE invention, the pressure drop over the meter is simply equal to a section of pipe with the same length.

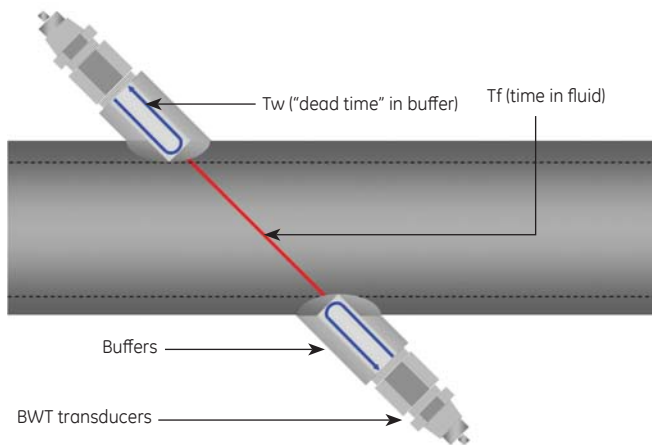

Built-in Flow Computer

Optionally the Sentinel SEN898 electronics have a built-in flow computer that allows for temperature, pressure and density corrections according to API MPMS 11.1. By connecting an external pressure, temperature and, if required, density measurement, all API corrections are done inside the SEN898 electronics, reducing the need for an external flow computer.

One-time Calibration

The Sentinel LCT requires a single calibration event (multi-viscosity or water, depending on the application) to work over the entire user flow range without the need for future calibrations or prover runs.

Advanced Electronics

Sentinel LCT has advanced digital signal processors that pack significant power in a simple package. Several output options are standard. The electronics can be mounted on the flowcell section or up to 50 feet away. Cable connections can easily be accessed, even when the meter has been mounted to a wall. HART is standard on all meters. Local diagnostics can be done via magnetic contacts through the glass, or by using the USB connection and our PanaView™ software.



PanaView™ for Diagnostics

PanaView software facilitates communication between a PC and the Sentinel LCT flowmeter. This software monitors the Sentinel flowmeter to provide a secure and comprehensive check on the meter configuration with a full audit trail. It also allows live flow readings and tracking of flow diagnostics.



Dimensions and Weights

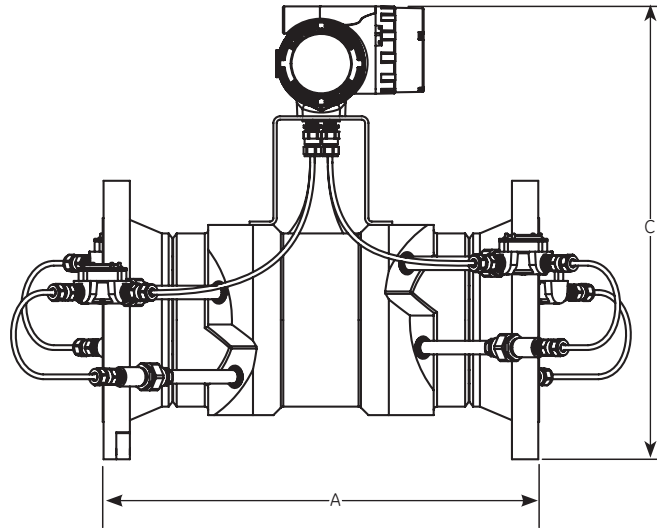
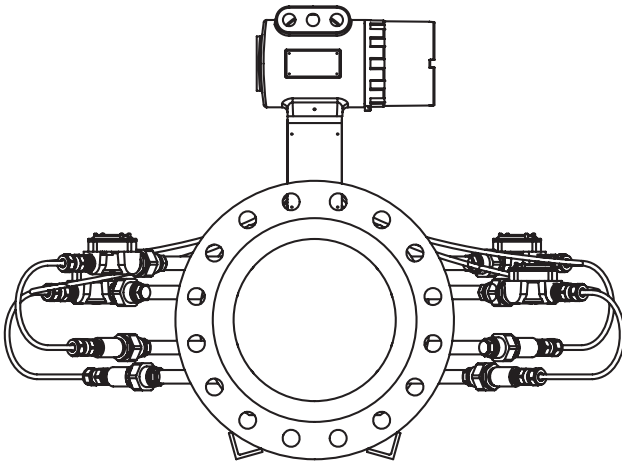

Weights are based on carbon steel.

Dimensions and weights in English units				
Diameter	Flange	A (in)	C (in)	Weight (lb)
4	150#	20	23.49	149
	300#	20	23.99	176
	600#	20	24.365	200
6	150#	22	25.76	209
	300#	24	26.51	265
	600#	26	27.26	338
8	150#	26	27.59	268
	300#	28	28.34	343
	600#	30	29.09	452
10	150#	28	29.84	367
	300#	30	30.59	487
	600#	32	31.84	739
12	150#	30	32.59	478
	300#	32	33.34	681
	600#	36	34.09	957
14	150#	36	34.09	790
	300#	38	35.09	1079
	600#	40	35.465	1339
16	150#	38	36.84	989
	300#	40	37.84	1348
	600#	42	38.59	1770
18	150#	38	37.84	1056
	300#	40	39.34	1527
	600#	44	39.965	2076
24	150#	48	44.59	1990
	300#	50	46.59	2947
	600#	52	47.09	3946

Dimensions and weights in metric units				
Diameter	Flange	A (mm)	C (mm)	Weight (kg)
4	150#	508	597	68
	300#	508	609	80
	600#	508	619	91
6	150#	559	654	95
	300#	610	673	120
	600#	660	692	153
8	150#	660	701	122
	300#	711	720	156
	600#	762	739	205
10	150#	711	758	166
	300#	762	777	221
	600#	813	809	335
12	150#	762	828	217
	300#	813	847	309
	600#	914	866	434
14	150#	914	866	358
	300#	965	891	489
	600#	1016	901	607
16	150#	965	936	449
	300#	1016	961	611
	600#	1067	980	803
18	150#	965	961	479
	300#	1016	999	693
	600#	1118	1015	942
24	150#	1219	1133	903
	300#	1270	1183	1337
	600#	1321	1196	1790

Specifications

Operation and Performance

Sentinel LCT has been designed to meet the OIML R117-1, MID MI-005 and API MPMS 5.8 requirements.

Fluid Types

Liquid Hydrocarbons

Flow Measurement

Correlation transit time mode

Accuracy

< ± 0.15% of measured volume for flow rates between 2 and 30 ft/s (0.5 and 10 m/s)

Repeatability

±0.02%

Uncertainty

< ± 0.027% according to API MPMS 5.8

Zero Stability

< 0.003 ft/s (0.0009 m/s)

Viscosity Range

0 to 500 cSt

Consult factory for higher viscosity numbers

Reynolds Range

> Re 5,000, consult factory for lower Reynolds numbers

Process Temperature

- 40° to +120°C (-40° to +248°F)

Ambient Temperature

- 40° to +60°C (-40° to 140°F)

Storage Temperature

- 40° to +80°C (-40° to +176°F)

Meter Body

Path Configuration

Four path Robust Path Configuration™

Meter Body Materials

- Carbon steel A105/A350LF2
- Stainless steel A182, Gr 304/304L
- Stainless steel A182, Gr 316/316L

Others on request.

Pipe Sizes

4 in (100 mm) to 36 in (900 mm)

Others on request.

Flange Ratings

- 150 #
- 300 #
- 600 #

Others on request.

Pipe Schedules

- 40S/STD
- 80S/XS

Others on request.

PED Compliance

PED Cat III, module H

Installation Requirement

Meter must be installed with 20D straight piping upstream and 5D straight piping downstream. Inlet and outlet piping shall match the meter ID within 1%. In case 20D inlet cannot be mounted, a 10D inlet with tube bundle flow conditioned could be applied.

Pressure, temperature and density connections must be located in the downstream piping. The 20D upstream piping (or 10D with flow conditioner) must be free of items that could disturb the flow profile.

Electronics

Electronics Enclosure Material

Epoxy coated aluminium

Dimension

- Weight: 25 lb (11.33 kg)
- Size (l x h x d): 13 x 11 x 9 in (33 x 28 x 23 cm)

Environmental Protection

IP66

Power Supply

- 100 to 240 VAC
- 12 to 32 VDC

Power Consumption

7 watt

Display

High contrast 128 x 64 pixel graphical display with LED illumination..

Outputs

- Two frequency/pulse outputs optically insulated from DC
- Two alarm relays
- One 4/20 mA output with HART

Inputs

Two 4/20 mA and one 100 ohm RTD input for density, pressure and temperature input (option). Three 4/20 mA inputs for density, pressure and temperature input (option).

Digital Interfaces

- HART over 4/20 mA output
- PanaLink over RS232/485/USB
- Modbus over RS232/485 (option)

Flow Computer Functionality

Integrated flow computer with full P and T volume corrections according to API 11.1

Hazardous Area Certifications

- USA/Canada: Class 1, Div 1, Groups B, C, & D
- Europe: ATEX II 2 G Ex de IIC (Ex d IIC as option)
- IEC Ex: Ex de IIC (Ex d IIC as option)

CE Compliance

2004/108/EC EMC Directive
2006/95/EC LVD

Custody Transfer Approvals

USA

Compliant with API MPMS 5.8

Europe

MID MI-005 by NMI (pending)

Rest of World

OIML R117-1 by NMI (pending)

The custody transfer approvals are valid for the flowmeter only. These approvals are not applicable for the built-in flow computer.

Flow Ranges

		0.5 m/s		10 m/s		0.5 m/s		10 m/s		0.5 m/s		10 m/s	
Nominal Diameter		1.69 ft/s		33 ft/s		1.69 ft/s		33 ft/s		1.69 ft/s		33 ft/s	
in	mm	(m ³ /h)	(m ³ /h)	(GPM)	(GPM)	(BBL/h)	(BBL/h)	(m ³ /h)	(m ³ /h)	(GPM)	(GPM)	(BBL/h)	(BBL/h)
4	100	15	280	66	1230	94	1760						
6	150	33	630	145	2770	207	3960						
8	200	58	1130	255	4980	364	7120						
10	250	91	1800	400	7900	573	11300						
12	300	131	2500	580	11000	825	15700						
14	350	179	3500	790	15400	1130	22000						
16	400	233	4500	1030	19800	1470	28300						
18	450	296	5700	1300	25100	1860	35900						
20	500	365	7000	1600	30800	2300	44000						
24	600	525	10000	2310	44000	3300	63000						

Typical flow rates for 0.5 m (19.6 in) per second and 10 m (393 in) per second are listed above. The Sentinel LCT is a full bore meter and the flow range is a function of the pipe and not the meter itself.

Sentinel Electronics SEN898 Ordering Information

SEN898 SEN 898 electronics for custody transfer measurement

Feature 1: Power

- 1 100 to 240 VAC operating voltage
- 2 12 to 32 VDC operating voltage

Feature 2: Inputs

- 0 None (not possible for LNG due to active temperature compensation)
- 1 One 100 ohm RTD input, Two 4-20mA inputs
- 2 Three 4-20mA inputs

Feature 3: Communications

- 0 None
- 1 Modbus RTU over RS232/RS485

Feature 4: Flow Computer

- 0 None (not possible for LNG due to active temperature compensation)
- API API correction of volume per API Chapter 11.1 (for LCT only, 3 inputs required)
- LNG Active compensation for tube contraction (for LNG only, 3 inputs required)

Feature 5: Explosion proof

- 1 USA/CAN explosion proof, Class 1, Div 1, groups B, C, D
- 2 European flameproof, II 2G Ex d IIC
- 3 European flameproof increased safety, II 2G Ex de IIC

Feature 6: Special Requirements

- 0 None
- S Special



Sentinel LCT Liquid Custody Transfer Flowmeter

SEN-LCT Sentinel Liquid Custody Transfer Flowmeter

Feature 1: Diameter

- 4 4" flowspool with RF flanges acc to ASME B16.5 (See Flow Rates table for metric conversion)
- 6 6" flowspool with RF flanges acc to ASME B16.5
- 8 8" flowspool with RF flanges acc to ASME B16.5
- 10 10" flowspool with RF flanges acc to ASME B16.5
- 12 12" flowspool with RF flanges acc to ASME B16.5
- 14 14" flowspool with RF flanges acc to ASME B16.5
- 16 16" flowspool with RF flanges acc to ASME B16.5
- 18 18" flowspool with RF flanges acc to ASME B16.5
- 20 20" flowspool with RF flanges acc to ASME B16.5
- 24 24" flowspool with RF flanges acc to ASME B16.5
- 28 28" flowspool with RF flanges acc to ASME B16.47 series A
- 30 30" flowspool with RF flanges acc to ASME B16.47 series A
- 32 32" flowspool with RF flanges acc to ASME B16.47 series A
- 36 36" flowspool with RF flanges acc to ASME B16.47 series A

Feature 2: Pressure Class

- 150 150 lbs pressure rating
- 300 300 lbs pressure rating
- 600 600 lbs pressure rating

Feature 3: Material

- CS Carbon steel, A105/A350LF2
- 304 Stainless steel, A182 Grade 304/304L
- 316 Stainless steel, A182 Grade 316/316L

Feature 4: Schedule

- 40S/STD Schedule size 40S/STD
- 80S/XS Schedule size 80S/XS
- S Special

Feature 5: Design Criteria

- A ASME B31.3
- P ASME B31.3 with PED approval

Feature 6: Electronics Mounting

- L Integrated local mounting
- S Remote mounting, cable length selectable (max 300 ft or 91 m)

Feature 7: Material Certs

- 0 None
- 1 Material certs
- 2 Material certs with EN 10204 3.1 inspection certificate

Feature 8: NACE Requirements

- 0 None
- 1 NACE MR0175
- 2 NACE MR0103

Feature 9: Special Requirements

- 0 None
- S Special

SEN-LCT



www.gesensinginspection.com

920-452B